

PLATFORM BASKET

SELF-PROPELLED AERIAL WORK PLATFORMS

J MAKE YOUR
JOB
EASIER

PERFECT
KILLER

SPIDER 150 A



SPIDER 150 A INGOMBRI MINIMI PER PRESTAZIONI ENORMI

150 A SPIDER MINI DIMENSIONS FOR HIGH PERFORMANCE

150 A ARAIGNEE DIMENSIONS MINIMALES POUR GRANDES PRESTATIONS



PRESTAZIONI SUPER SUPERIOR PERFORMANCES SUPER PERFORMANCES

Sbracci elevati in funzione del carico in navicella con una estensione massima di mt. 8,50 con 120 Kg.

Big working envelope, providing a maximum outreach of 8,50 m. with 120 Kg in the cage

Grandes extensions en fonction de la charge dans le panier avec une extension max de m. 8,50 avec 120 Kg.



VERSATILITA' VERSATILITY VERSATILITE

Permette, grazie agli ingombri minimi, a macchina ricoverata, di accedere a spazi angusti o attraverso porte.

Thanks to the compact dimensions of the machine when in the stowed position, it can access narrow locations and pass through doorways.

Permet, grace aux dimensions reduites, avec machine a repos, l'acces a espaces etroits ou travers des portes.



MINIMI INGOMBRI MINIMUM DIMENSIONS DIMENSIONS MINIMUM

Permette di poter operare, a macchina stabilizzata, in spazi ristretti con la massima sicurezza.

Allows the machine to operate with the outriggers deployed in maximum safety.

On peut travailler, avec la machine stabilisee, en espaces etroites avec la max securite.



JIB +/- 45° JIB + OR - 45° JIB + OU - 45°

Permette una grande flessibilità durante l'uso della piattaforma nel caso di ostacoli.

Allows greater manoeuvrability and precise positioning, particularly over obstacles.

Il permet une grande flexibilité pendant l'emploi de l'elevateur en case d'obstacles.



COMANDI IDRAULICI HYDRAULIC CONTROLS COMMANDES HYDRAULIQUES

Permettono l'utilizzo della piattaforma semplificando quelle che sono le problematiche legate ai comandi elettro-idraulici.

They allow the use of the platform simplifying the problems connected to the electro-hydraulic contr.

Ils permettent l'emploi de l'elevateur en simplifiant les problemes lies aux commandes electro-hydrauliques.



TRASPORTO TRANSPORT TRANSPORT

Facilità di carico su mezzi di piccole dimensioni con ausilio di rampe.

Can be easily transported because of the low machine weight and the ability to climb ramps.

Facilité de charge sur vehicules de petites dimensions avec des rampes

CARATTERISTICHE TECNICHE

TECHNICAL FEATURES

CARACTERISTIQUES TECHNIQUES

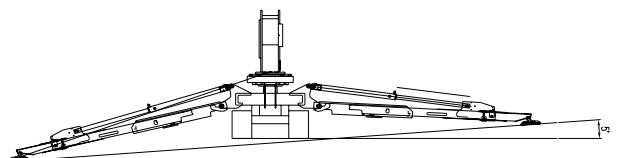
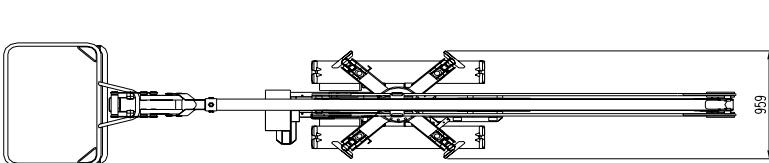
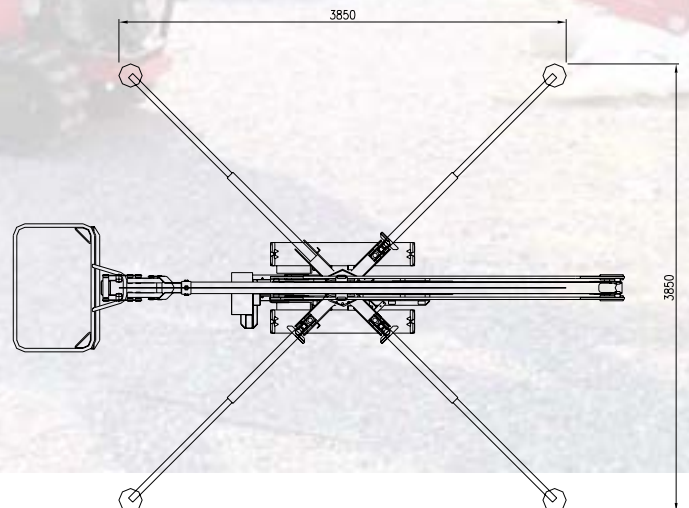
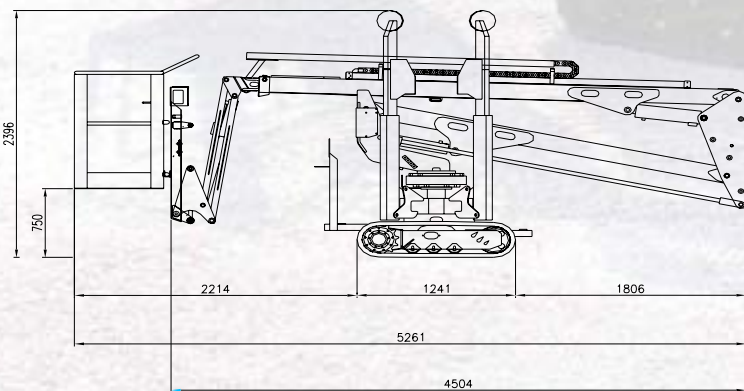
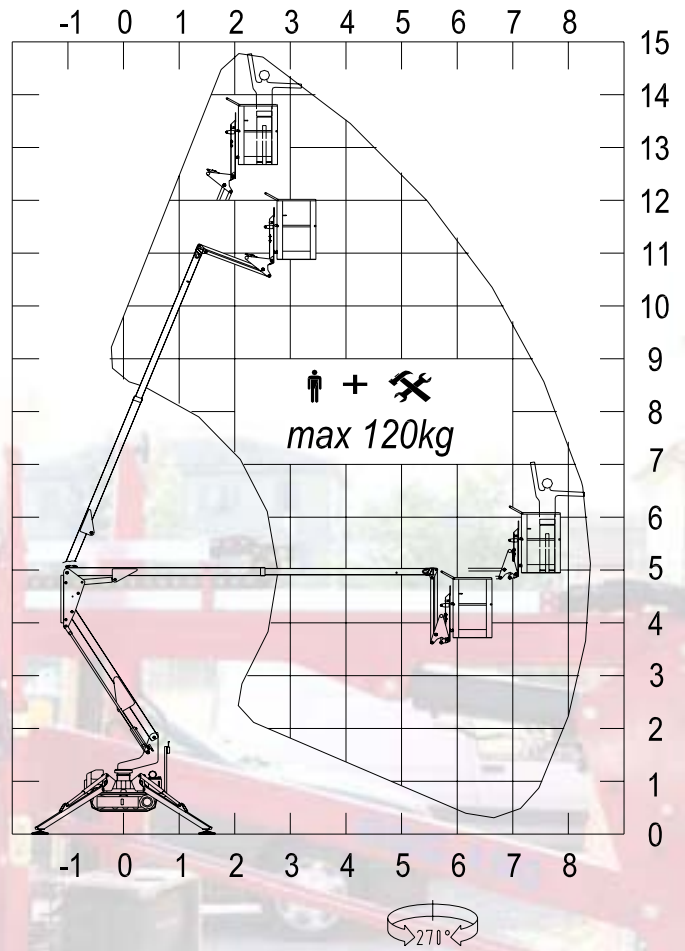
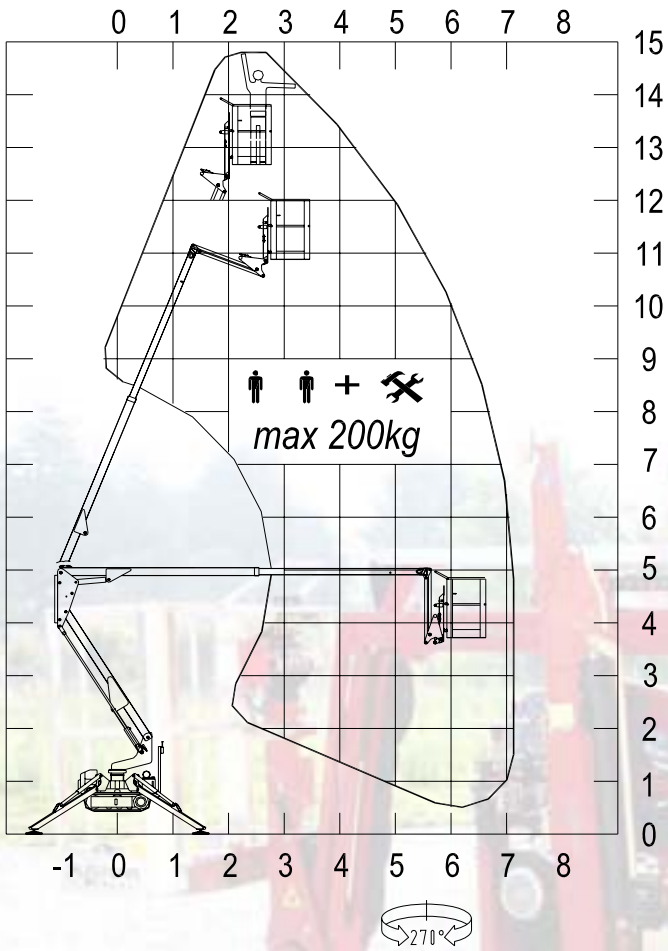

PLATFORM BASKET

SELF-PROPELLED AERIAL WORK PLATFORMS

CARATTERISTICHE STANDARD/STANDARD FEATURES

CARACTERISTIQUES STANDARD

Pompa a mano d'emergenza
Emergency hand pump
Pompe manuelle d'urgence

Valvole di blocco su tutti gli attuatori
Lock valves on all the actuators
Valves de blocage sur les actuateur

Contaore
How-meter
Computer-horaires

Interblocco bracci/stabilizzatori
Stabilisers/booms interblock
Interblocage stabilisateurs/bras

Limitatore di carico
Load limiting device
Limiteur de charge

Cingoli in gomma nero
Black rubber tracks
Chenille en caoutchuc noir

OPTIONALS/OPTIONALS/OPTIONS

Elettropompa 110/220/380 V
110/220V/380V Motor pump
Electropompe 110/ 220/380V

Elettropompa d'emergenza 12 V
Emergency motor pump 12V
Electropompe d'urgence 12V

Presa aria acqua in navicella
Air water outlet in the cage
Prise air eau dans le panier

Presa di corrente 220V in navicella
220V outlet in the cage
Prise électrique dans le panier

Cingoli antitraccia
No marking tracks
Chenilles pas marquants

Cingoli estensibili
Extendible tracks
Chenilles extensibles

Colori personalizzati
Personal colours
Couleur personnalisee

Kit anticollisione
Anti-collision kit
Kit anti-collision

CARATTERISTICHE TECNICHE/TECHNICAL FEATURES

CARACTERISTIQUES TECHNIQUES

Altezza di lavoro
Working height
Hauteur de travail 15.00 m.

Altezza di calpestio
Working height to the basket floor
Hauteur de travail au plancher 13.00 m.

Sbraccio laterale
Side outreach
Déport laterale 8.50 m./120 Kg.
7.20 m./200 Kg.

Rotazione torretta
Turret rotation
Rotation tourelle 270°
270°
270°

Dimensioni navicella
Cage dimensions
Dimensions panier 1.10x0.70x1.10 m.

Lunghezza massima
Max length
Max longueur 4.50/5.26 m.

Larghezza max
Max width
Max largeur 0.96 m.

Altezza a riposo
Height in stowed position
Hauteur a machine repliee 2.39/1.92 m.

Ingombro macchina stabilizzata
Overall dimensions with stabilised machine
Encombrement machine stabilisee 3.85 m.

Velocità traslazione
Driving speed
Vitesse de déplacement 0-2.5 Km./h

Pendenza massima
Gradeability
Pente max 25%

Portata massima
Max capacity
Max capacite 200 Kg.

Motore benzina
Petrol engine
Moteur a essence 9 Kw.

Motore Diesel
Diesel engine
Diesel moteur 9 Kw.

Peso totale macchina base
Total weight of the machine
Poids total de la machine Kg 2000

PLATFORM BASKET
SELF-PROPELLED AERIAL WORK PLATFORMS

Uffici e Sede Operativa: Via Grande 27 - 42028 Poggio (RE) Italy

Tel. 0522-967666 Fax 0522-967667

e-mail: info@platformbasket.com

www.platformbasket.com

RIVENDITORE

Dati dimensioni caratteristiche sono forniti a titolo indicativo e non impegnativo la PLATFORM BASKET si riserva il diritto di effettuare qualsiasi modifica senza alcun preavviso. Tutti i diritti sono di proprietà della PLATFORM BASKET ogni abuso verrà perseguito a norma di legge.

Data dimensions and features are indicative and not binding. Platform Basket reserves the right to do any changes without notice. All the rights belong to PLATFORM BASKET. Any abuse will be pursued following the rule of law.

Les donnees les dimensions les caracteristiques sont donnees a titre indicatif et n'engage pas le maison. PLATFORM BASKET se reserve le droit d'effectuer toutes les modifications sans preavis. Tous les droits sont de propriété de PLATFORM BASKET et chaque abus sera poursuivi aux termes de la loi.